

 **KTH IW-3E**
AUTOMATIC DOOR SYSTEM

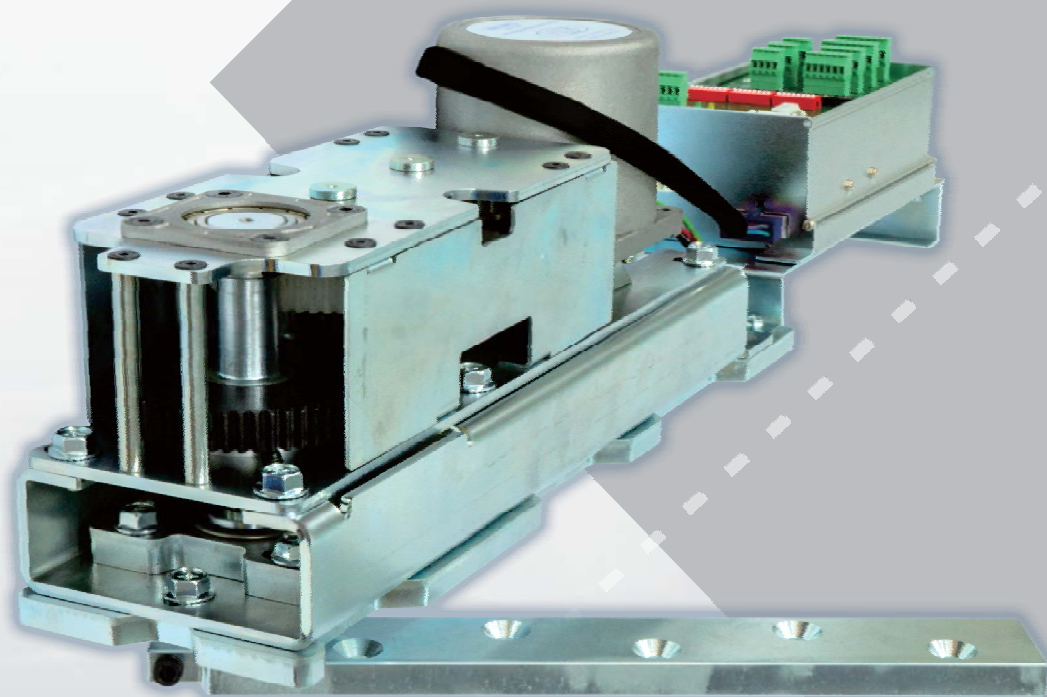

■ TABLE OF CONTENTS

1.SPECIFICATION.....	1
2.OPERATOR (SECTION).....	2
3. DESCRIPTION of OPERATOR.....	3
4. EN16005	
4-1.ADJUST BOARD INSTRUCTION.....	4 & 5
4-2.CONNECTION-ACTIVATION AND LOCKS.....	6
4-3.CONNECTION-SAFETY.....	7
4-4.DOUBLE DOOR AND MASTER/SLAVEFUNCTION	8

1 SPECIFICATION

MODEL	IW-3E
MOTOR	DC 24V 120W BRUSHLESS DC MOTOR
CONTROL	STANDARD MICRO-CONTROL
POWER CONSUMPTION	120W
VOTAGE	AC100V~240V
ENVIRONMENTAL TEMPERATURE	-20°C~+50°C
VOLUME	55 decibel(max.)
SPEED of OPENING 90 DEGREE	3~8 sec. /90° (max.)
STARTING TIME	0~20 sec. (Regulable)
OPENING DOOR RANGE	120°(Max.)/90°(default)
POWER EFFICIENCY	0.95 (In full load)
TRACTION FORCE	2.5 kg

2 OPERATOR (SECTION)

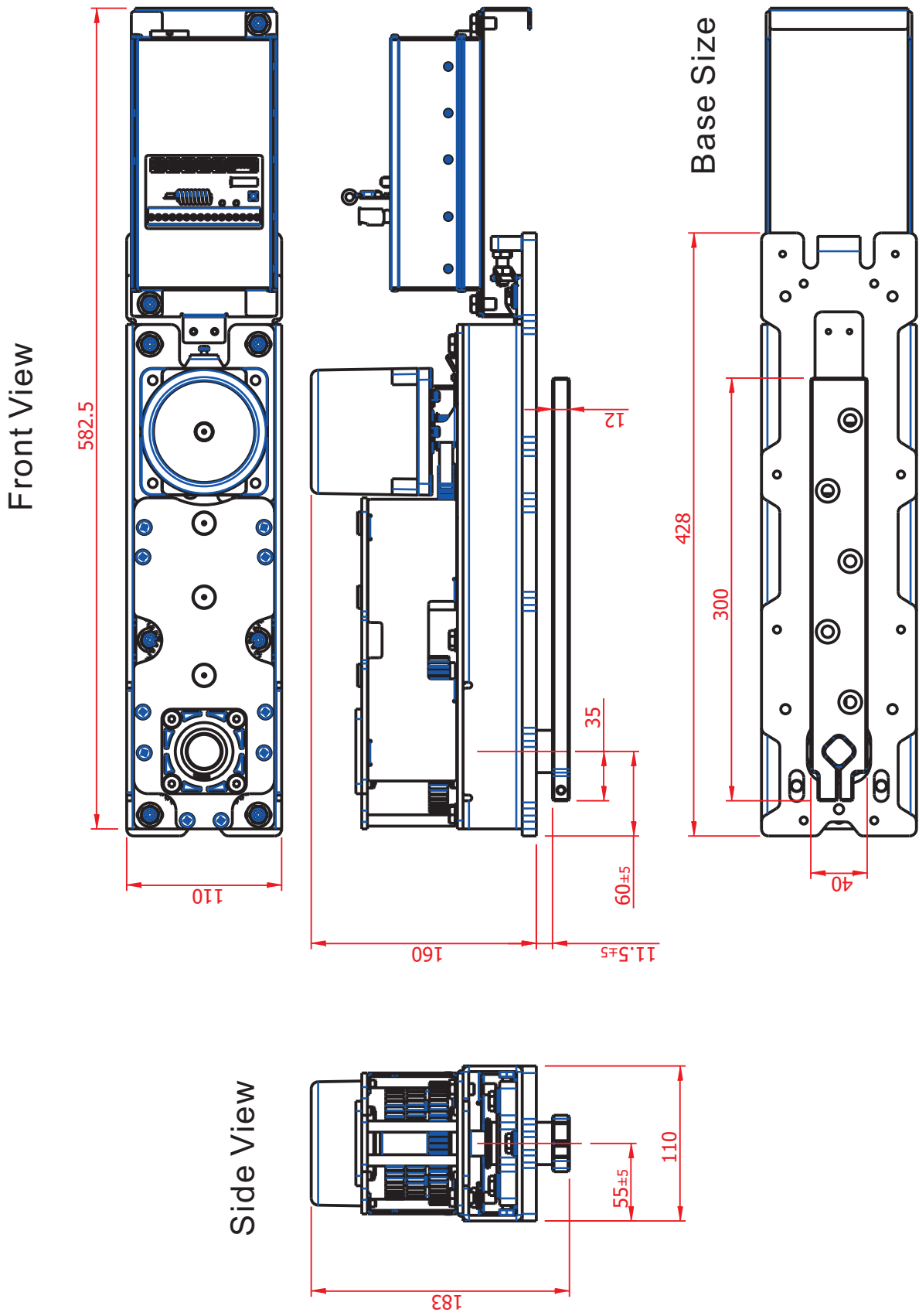

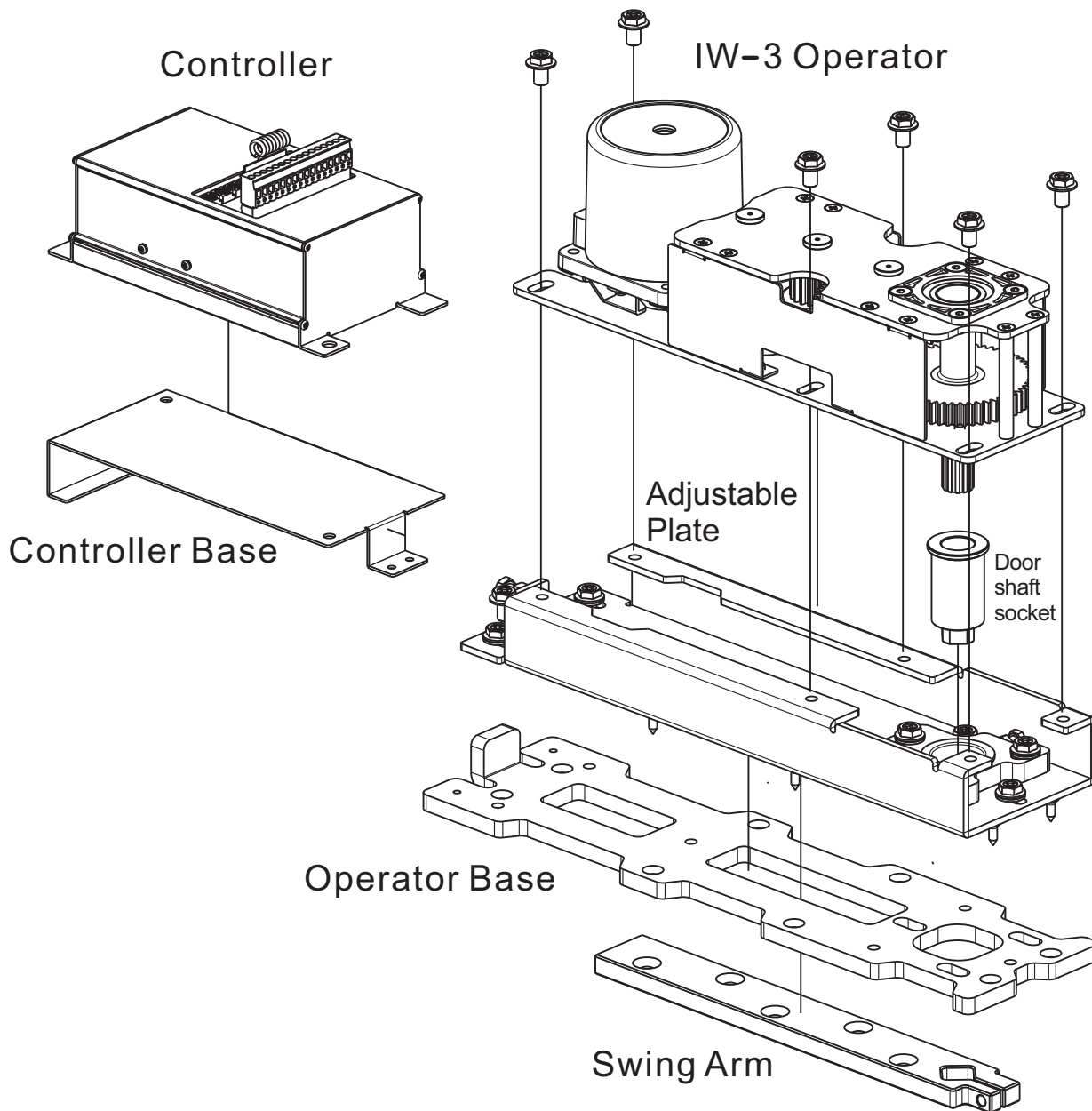

4-1 ADJUST BOARD INSTRUCTION (EN16005)

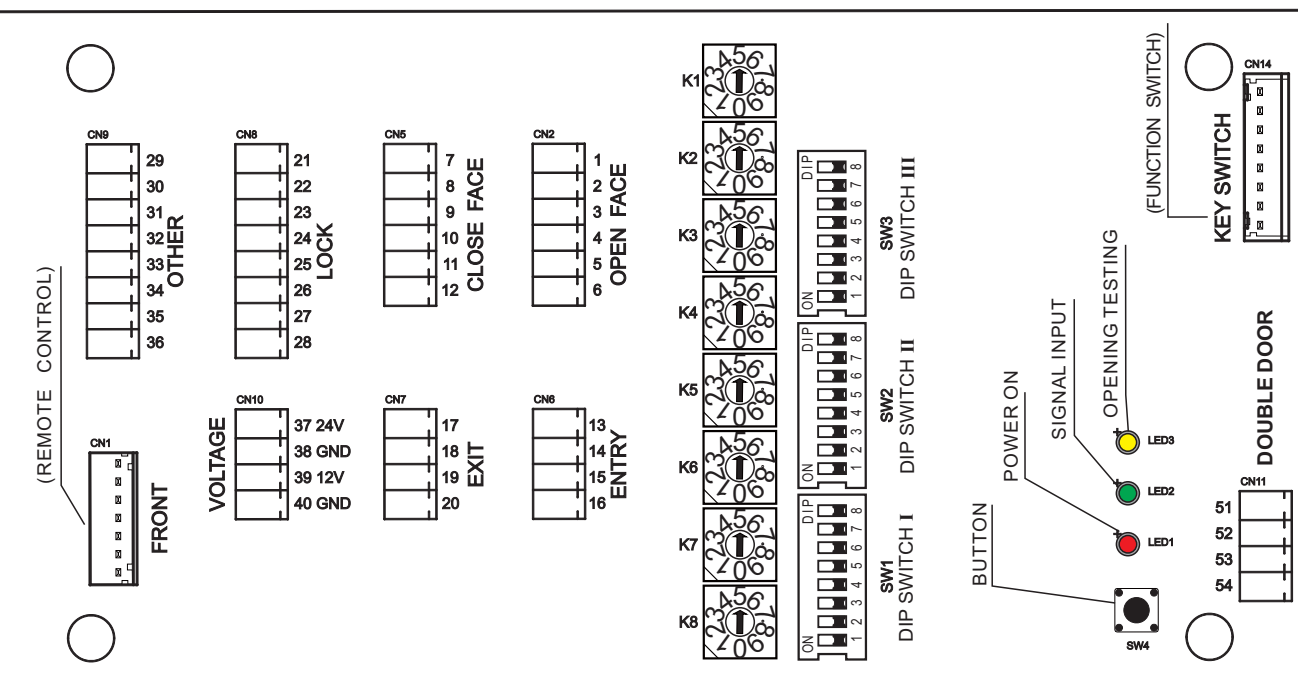

K1 Opening Speed

Adjust the OPENING SPEED. Higher number, faster speed.
CAUTION: please adjust the number one by one from **low to high**.

K2 Closing Speed

Adjust the CLOSING SPEED. Higher number, faster speed.
CAUTION: please adjust the number one by one from **low to high**.

K3 Slowing Speed of Opening Door

Adjust the SLOWING SPEED OF OPENING DOOR. Higher number, greater strength.
CAUTION: please adjust the number one by one from **high to low**.

K4 Slowing Speed of Closing Door

Adjust the SLOWING SPEED OF CLOSING DOOR. Higher number, greater strength.
CAUTION: please adjust the number one by one from **high to low**.

K5 Opening hold time

Adjust the HOLD OPEN TIME. Higher number, the hold time is longer.

NUMBER	0	1	2	3	4	5	6	7	8	9
SECOND	0	1	2	3	5	10	15	20	60	120

K6 Sensitivity of Collision Detection

Adjust the sensitivity of reaction to obstacle during door is working, less number, higher sensitivity.
CAUTION: please adjust the number one by one from **low to high**.

K7 Brake Power

Adjust Door-Leaf BRAKE POWER. Higher number, more Brake power

K8 "Non-detect angle" for safety sensor

NUMBER	0	1	2	3	4	5	6	7	8	9
ANGLE	Disable	4/90°	8/90°	12/90°	16/90°	20/90°	24/90°	28/90°	32/90°	36/90°

Yellow LED : Opening Testing
Green LED : Signal input.
Red LED : Power on.

DIP Switch I

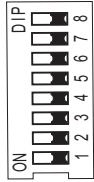

1 L/R Switch
 Right Left

2 Brake power switch
 OFF ON

3 SLAVE postpone angle range
 Little Large
 *Please ref. to P13

4 Directional function
 OFF ON
 OFF: Normal mode.
 ON: Push once, open the door.
 Push again, close the door.

5 MASTER/SLAVE setting
 Master Slave

6 Electric lock type setting
 Normal Spring Latch

7 Reset/learn setting
 Reset learn

8 Reverse Switch:
 in order to control opening and closing direction of the Door-Leaf after power resumes.
 OFF ON
 OFF: Normal mode, after power resumes, the Door-Leaf opens the door first.
 ON: suitable for Security System, after power resumes the Door-Leaf closes the door first.

DIP Switch II



1 Open Face Safety
 N.O N.C

2 Open Face Safety Test
 No Yes

3 Open Face Safety Type
 Stop Slowly

4 Closing Face Safety
 N.O N.C

5 Closing Face Safety Test
 No Yes

6 Entry Sensor
 N.O N.C

7 Exit Sensor
 N.O N.C

8 Emergency stop
 N.O N.C

DIP Switch III

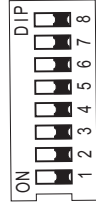

1 Open
 N.O N.C

2 Fire Alarm
 N.O N.C

3 Fire Alarm Type
 Open Close

4 ~ 8 Standby

4-2 CONNECTION-ACTIVATION AND LOCKS (EN16005)

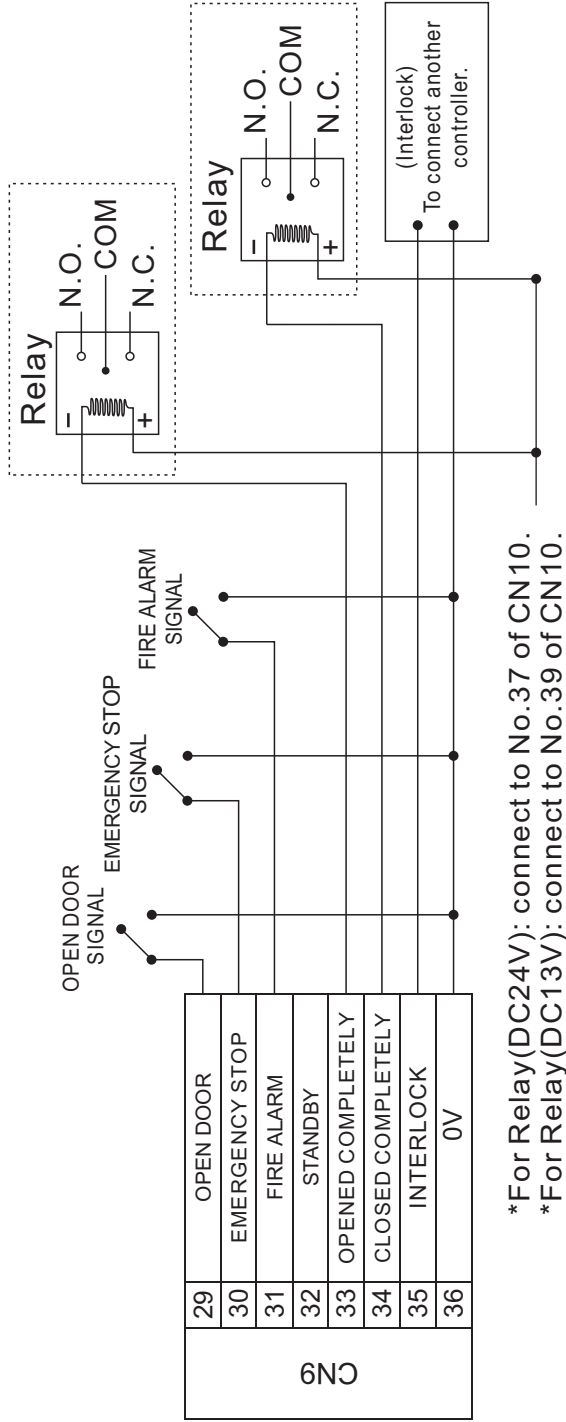

Warning

- * Relay it should be with built in diode.
- * Relay Suggested model: OMRON MY2N-D2-J (it's arranged by customers)

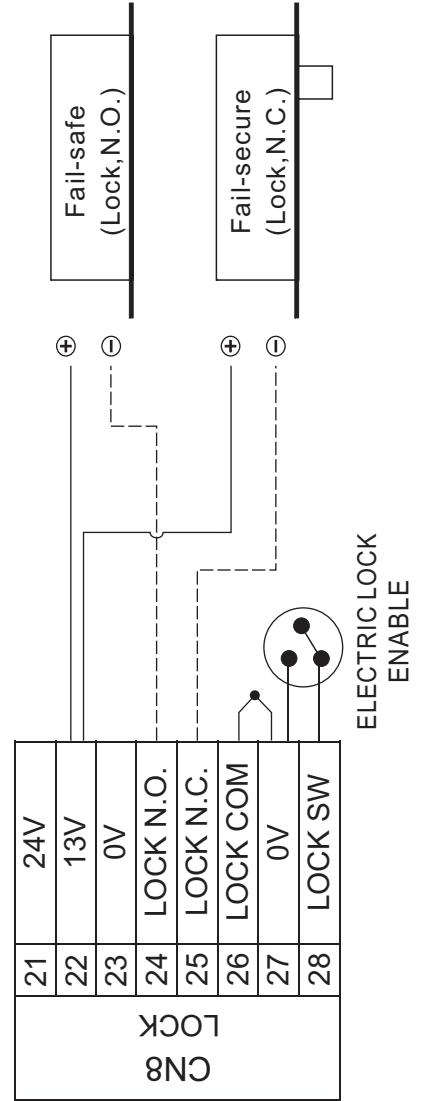

4-3 CONNECTION - SAFETY (EN16005)

ENTRY SENSOR ACTIVATION

CN6			
13	14	15	16
24V	COM	COM	N.O

+	-	COM	N.O
---	---	-----	-----

HR50

EXIT SENSOR ACTIVATION

CN7			
17	18	19	20
24V	COM	COM	N.O

+	-	COM	N.O
---	---	-----	-----

HR50

PREMIER SWING ONDOOR SAFETY (NOT MONITORED)

CN2					
1	2	3	4	5	6
24V	COM	COM	ACT	TEST-	TEST+

POW	POW	COM	N.C	TEST-	TEST+
1	2	3	5	6	7

HOTRON SSS-5

CN5					
7	8	9	10	11	12
24V	COM	COM	ACT	TEST-	TEST+

POW	POW	COM	N.C	TEST-	TEST+
1	2	3	5	6	7

HOTRON SSS-5

OPEN FACE SAFETY (TOPSCAN)

CONTROLLER PANEL
DIP Switch II No.1 → "ON"
SSS-5
DIP Switch No.1 → "B"
No.3 → "N.C"

CLOSE FACE SAFETY (TOPSCAN)

CONTROLLER PANEL
DIP Switch II No.4 → "ON"
SSS-5
DIP Switch No.1 → "B"
No.3 → "N.C"

PREMIER SWING ONDOOR SAFETY (MONITORED)

CN2					
1	2	3	4	5	6
24V	COM	COM	ACT	TEST-	TEST+

POW	POW	COM	N.C	TEST-	TEST+
1	2	3	5	6	7

HOTRON SSS-5

CN5					
7	8	9	10	11	12
24V	COM	COM	ACT	TEST-	TEST+

POW	POW	COM	N.C	TEST-	TEST+
1	2	3	5	6	7

HOTRON SSS-5

OPEN FACE SAFETY (TOPSCAN)

CONTROLLER PANEL
DIP Switch II No.1 → "ON"
No.2 → "ON"
SSS-5
DIP Switch No.1 → "A"
No.3 → "N.C"

CLOSE FACE SAFETY (TOPSCAN)

CONTROLLER PANEL
DIP Switch II No.4 → "ON"
No.5 → "ON"
SSS-5
DIP Switch No.1 → "A"
No.3 → "N.C"

4-4 DOUBLE DOOR AND MASTER/SLAVE FUNCTION (EN16005)

A. Double Door

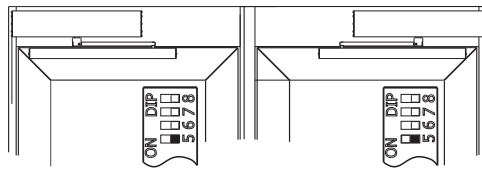

Please set all door DIP Switch I No.5 Off.

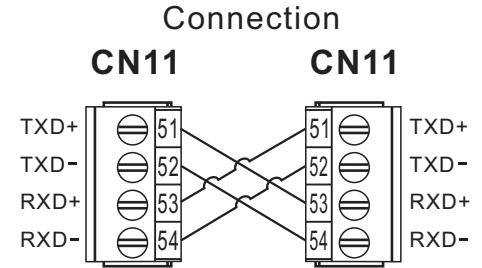

After connecting to terminals, yellow LED flashes to indicate connecting properly. The door leaves will open and close at the same time.

B. Double Door

M/S

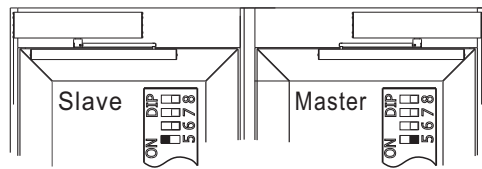

Please set the door which closes first to master (DIP Switch I → No.5 Off), then set the second to close to slave (DIP Switch I → No.5 On).

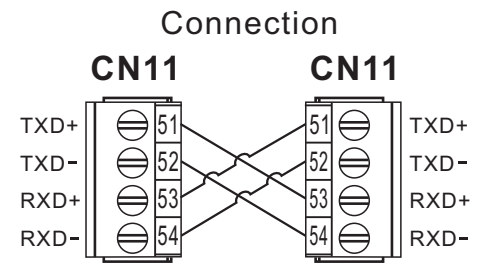

Slave

Master

After connecting to terminals, yellow LED flashes to indicate connecting properly.

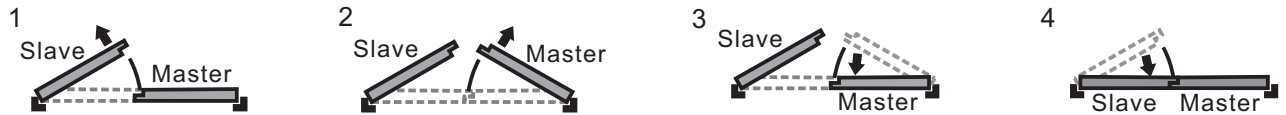

⊗ Before turn on the power, please inspect the relative positions of the door leaves to avoid error occurs. Please turn on "Master" and "Slaver" at the same time to avoid the time different causes the error.

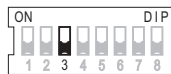

DIP Switch I

SLAVE postpone angle range

When MASTER door is closing in order to avoid the SLAVE door hit it, installer can set the range to postpone the position to SLAVE.

Setting Little

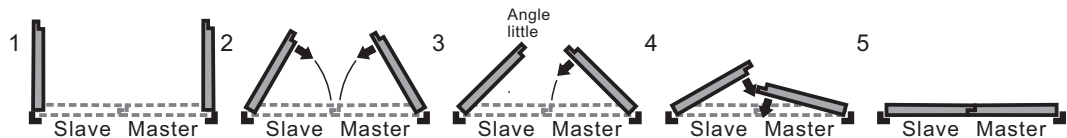

Setting Large

