

KTH H-18
AUTOMATIC DOOR SYSTEM



■ TABLE OF CONTENTS

1. SPECIFICATION&PROFILE	1
2. COMPONENTS	2
3. THE POSITION OF THE HANGING TWIN-WHEEL	3
4. INSTALL THE RACK BELT.....	4
5. LEGEND OF PART DRAWING	5
6. TEST AND ADJUST	6
7. ADJUST CONTROLLER	7
8. TH-125 (NEW)-REMOTE CONTROL TH-136-MULTIFUNCTION DIGITAL SWITCH.....	8
9. HTP-21C SAFETY BEAM & HR942D SENSOR.....	9
10. HR100-CT SENSOR	10
11. HR94D1-C1SENSOR	11
12. TH-201&TH-200LK LOCK	12
13. TH-135-FUNCTION KEY SWITCH	13

SPECIFICATION & PROFILE

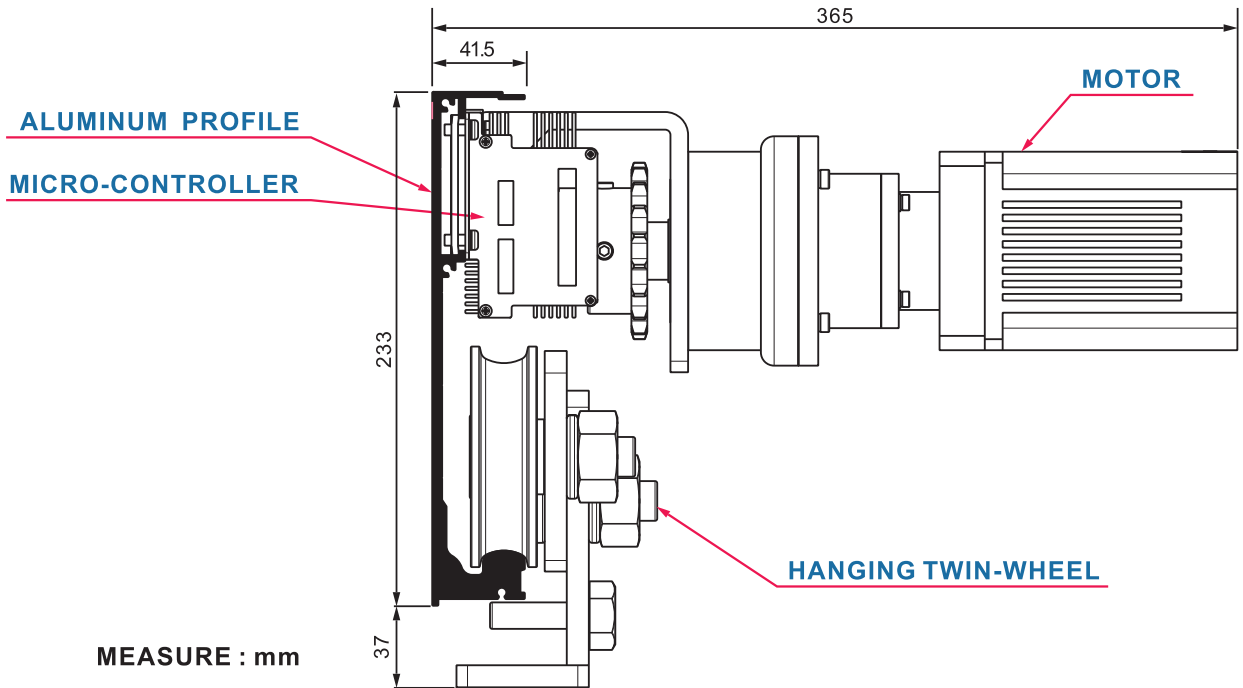

TYPE	H-18	
MODEL	SINGLE-WINGED	BI-PARTING
DOOR WEIGHT	1000kg X1(DOOR)	900kg X2(DOOR)
DOOR WIDTH	500mm~6000mm	500mm~6000mm
INSTALL WAY	SURFACE INSTALL	SURFACE INSTALL
MOTOR	DC24V 180W BRUSHLESS DC MOTOR (PLANETARY GEAR)	
CONTROL	STANDARD MICRO-CONTROL	
POWER CONSUMPTION	180W	
VOLTAGE	AC100V~240V	
ENVIRONMENTAL TEMPERATURE	-20°C~+50°C	
VOLUME	65 DECIBEL(MAX.)	
STARTING SPEED	300mm/SEC.	250mm/SEC.
STARTING TIMES	0~20 SEC. (REGULABLE)	
TRANSMISSION IMPORTANT CONDITION	ROLLER CHAIN 40-1R	
OPENING DOOR RANGE	FULL/HALF-OPEN (REGULABLE)	
PFC POWER EFFICIENCY	0.95(IN AC100V FULL LOAD)	
TRACTION FORCE	WHEN POWER OFF THE DOOR CAN BE OPENED BY MANUAL	

COMPONENTS



MICRO-CONTROLLER

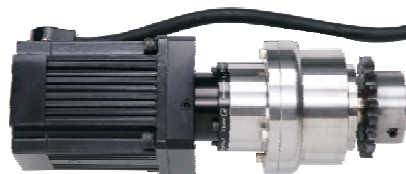

BRUSHLESS DC MOTOR

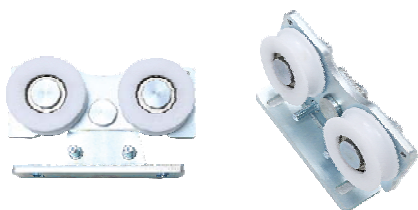

**HANGING TWIN
WHEEL-4PCS**



BELT ROLLER



POWER SWITCH



**SENSORS
(OPTIONAL DEVICE)**



MOTOR HOLDER



**STOPPER -2PCS
(IN PROFILE)**

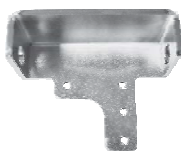

ACTIVE BRACE



PASSIVE BRACE

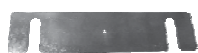

MEDIUM-10PCS



**ACTIVE & PASSIVE
SCREW**



**DOOR
SCREW-8 PCS**



**WIRE
CLAMP-5 PCS**



CHAIN

THE POSITION OF THE HANGING TWIN-WHEEL

Bi-parting

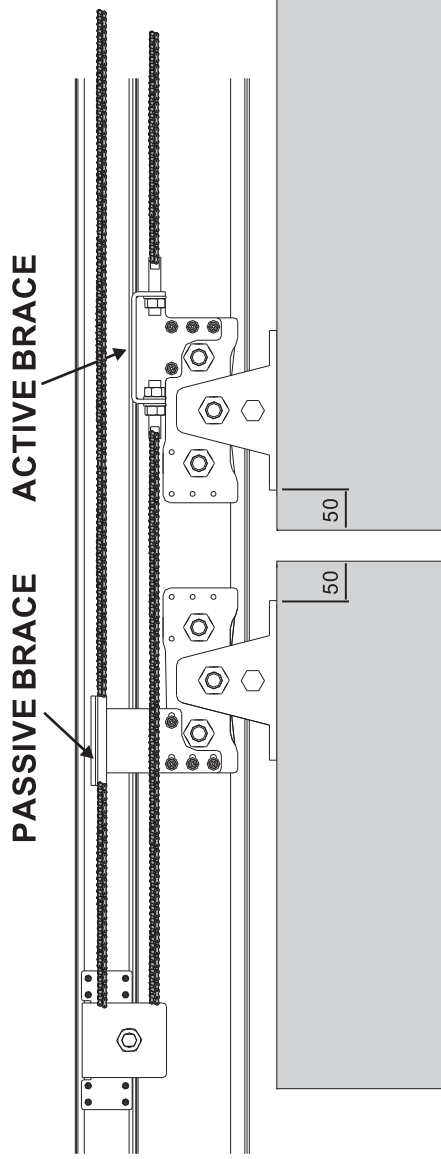

In order to open to the largest position. Please leave 50mm between the edge of door leaves and hangers

Single-winged

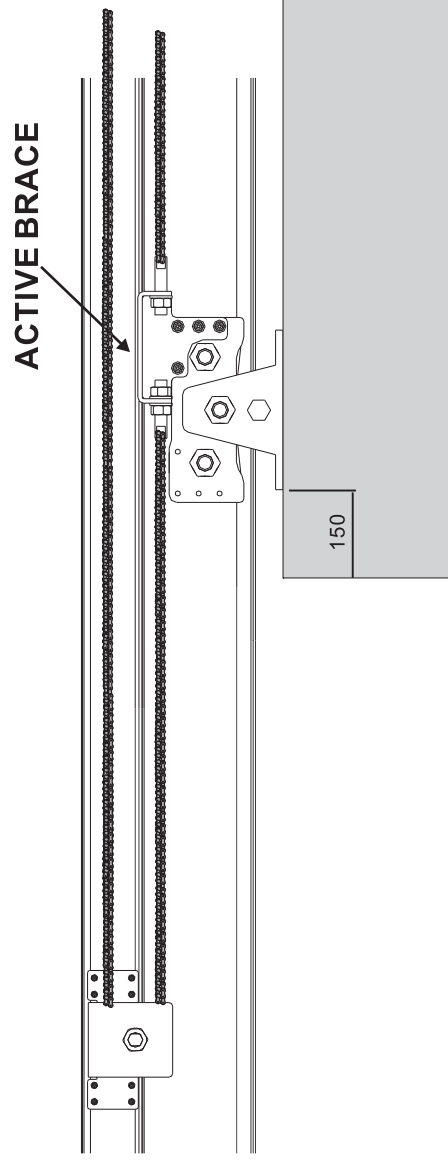

MEASURE : mm

In order to open to the largest position. Please leave 150mm between the edge of door leaf and left hanger.

■ INSTALL THE RACK BELT

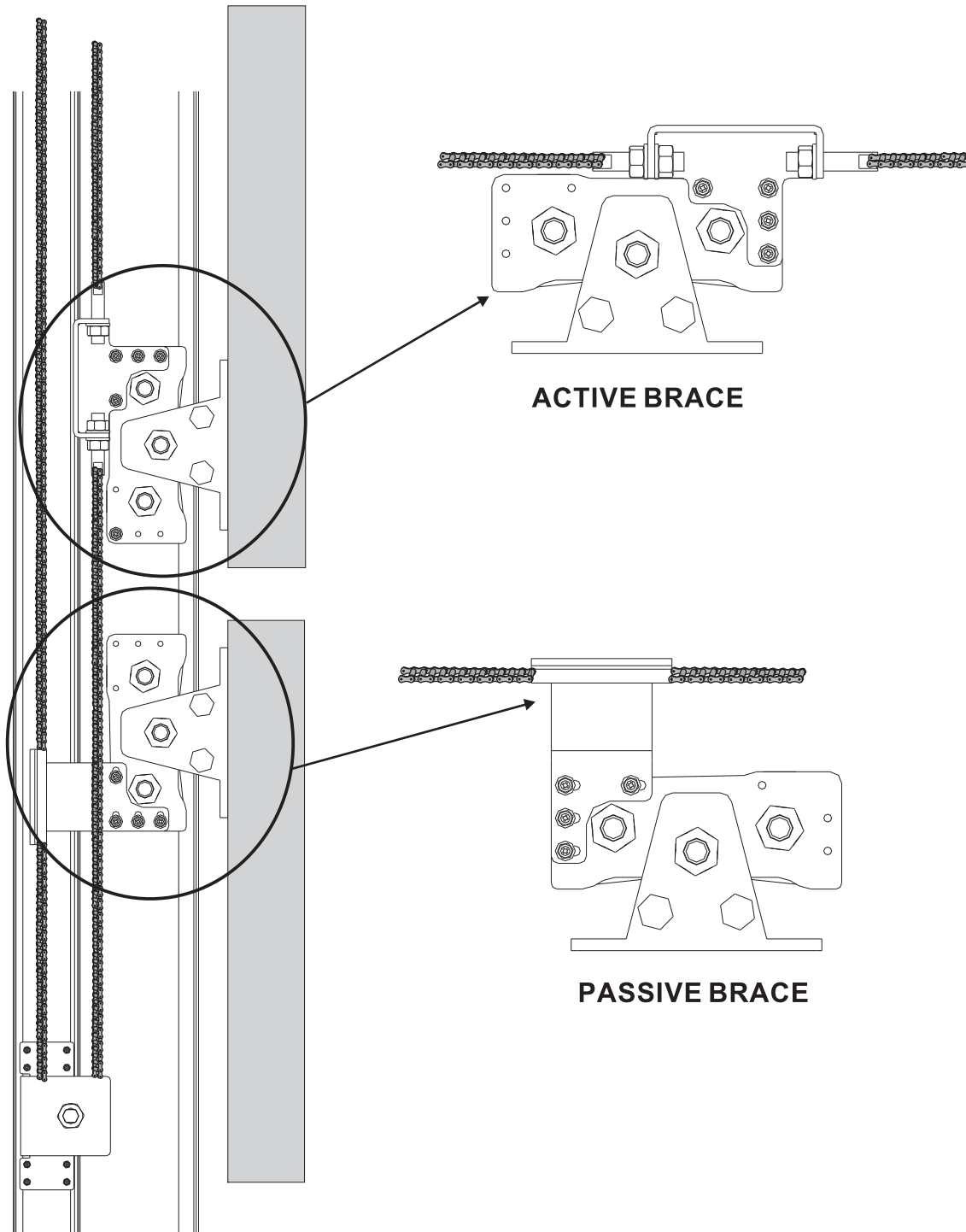

■ LEGEND OF PART DRAWING

Parts List		
No.	Parts Name	Quantity
1	"Standard" aluminum profile	1
2	Motor	1
3	Controller	1
4	Rack belt	1
5	Hanging-wheel	4
6	Active brace	1
7	Passive brace	1
8	Chain roller </td <td style="background-color: #cccccc;">1</td>	1
9	Stopper	2
10	Power switch	1
11	Chain brace	1

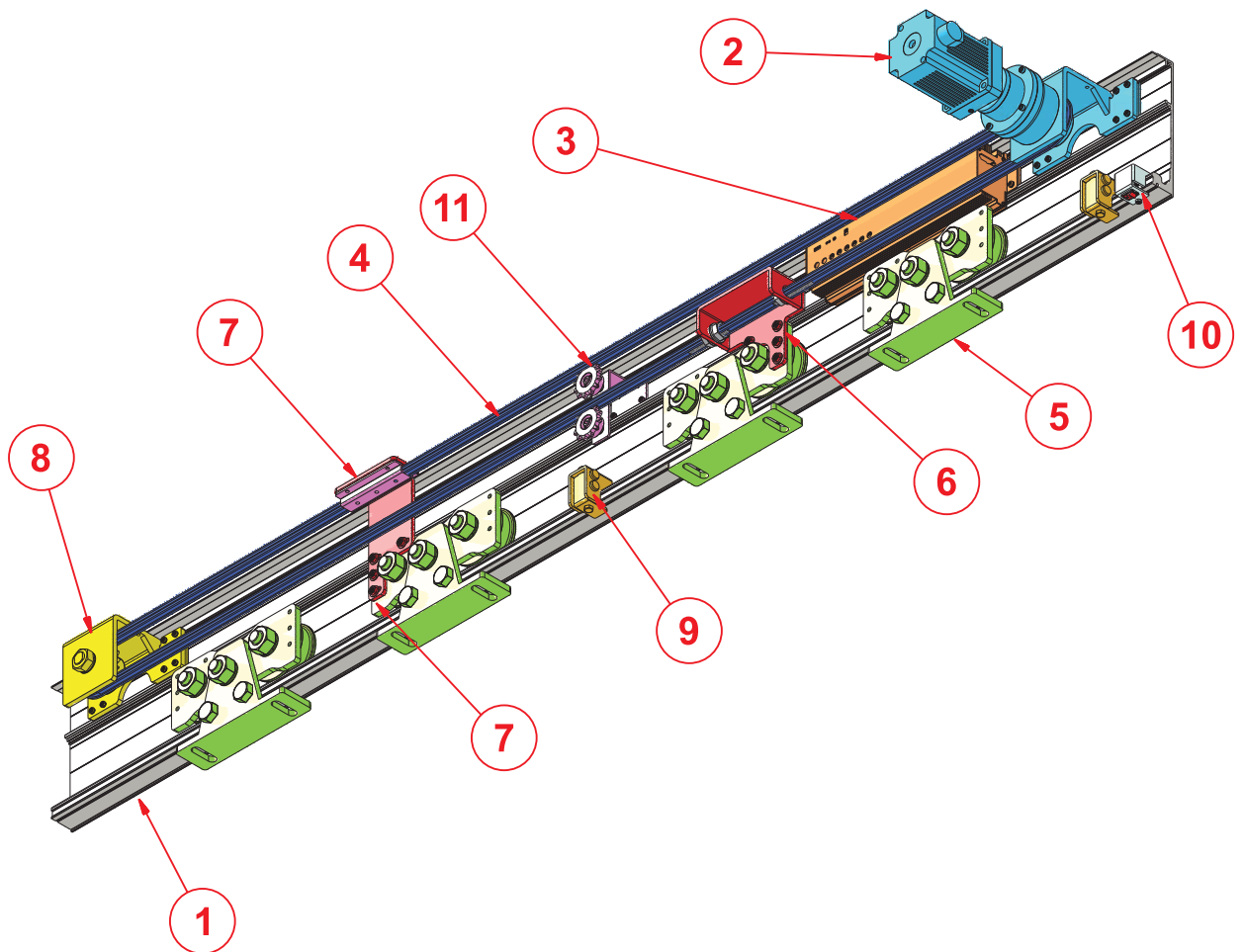

TEST AND ADJUST

The FACEPLATE of MICRO-CONTROLLER

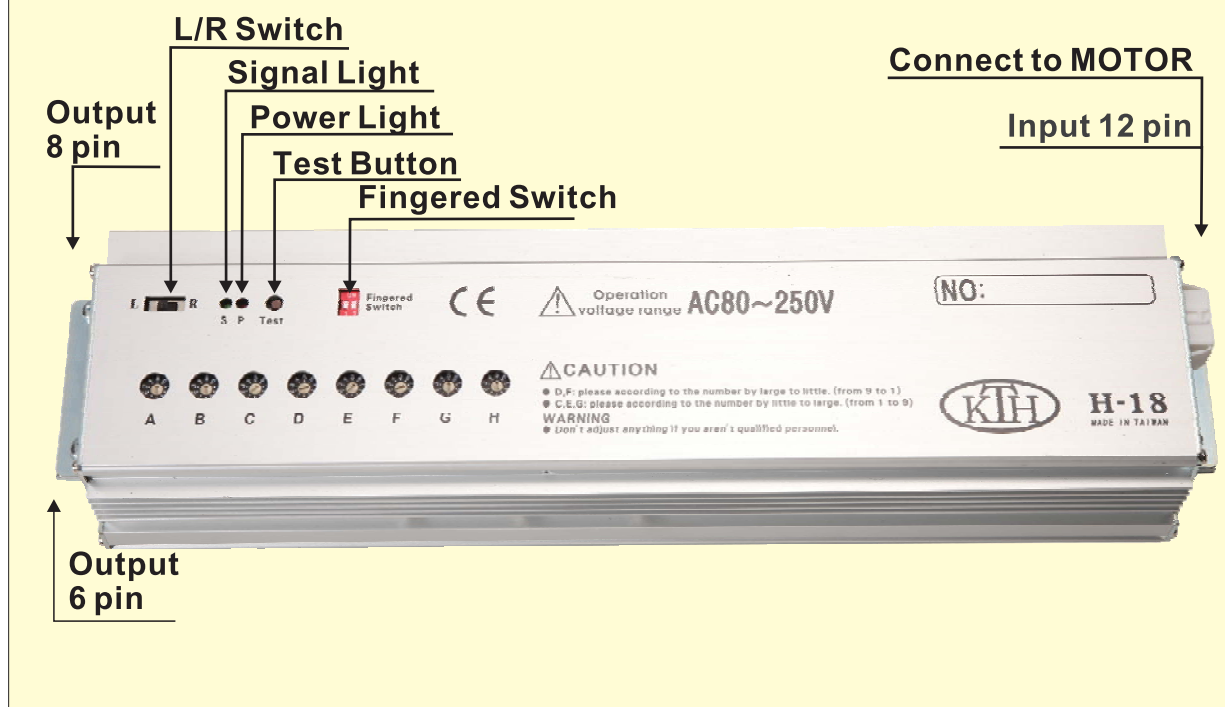

Red LED-Power is connected.

Green LED-Input the open door signal.

L/ R switch- The direction of the door opening: right/left(R/L).

Fingered Switch- Pin 1- Directional Function

Fingered Switch- When the pin 1 is ON, push once:open the door.

Push again: close the door.

Fingered Switch- When the Pin 2 is standby.

ADJUST CONTROLLER



A Full/Half opening

Adjust the RANGE of the HALF OPEN DISTANCE.
Higher number, wider range.



B Brake power

The Door-Leaf is slight, the BRAKE POWER is less.



C The opening speed of the door

Adjust the OPEN SPEED
Higher number, faster speed.
CAUTION: please adjust the number one by one from low to high.



D The slowing range of opening door

Adjust the SLOW RANGE of OPENING DOOR
Higher number, more range about the slow range at open door position.
CAUTION: please adjust the number one by one from high to low.



E The closing speed of the door

Adjust the CLOSED SPEED
Higher number, faster speed.
CAUTION: please adjust the number one by one from low to high.



F The slowing range of closing door

Adjust the SLOW RANGE of CLOSED DOOR
Higher number, more range about the slow range at open door position.
CAUTION: please adjust the number one by one from high to low.



G The slowing speed of the door

Adjust the SLOW SPEED
Higher number, faster speed.
CAUTION: please adjust the number one by one from low to high.



H Opening hold time

Adjust the HOLD OPEN TIME
Higher number, the hold time is longer.

NUMBER	0	1	2	3	4	5	6	7	8	9
SECOND	0	1	2	3	4	5	6	10	15	20

■ TH-125 (NEW)-REMOTE CONTROL

1. Transmitter is 20 bit digital code that is much safety and use fix-frequency component to transmit signal. The frequency of transmitter won't be affected by battery consumption and outside environment.
2. Wireless receiver use super-heterodyne from U.S.A..
The receiver is stably, anti-interference, no extra-wave.
3. Control unit is 8 bit single chip. The order is accurate and action is correct.

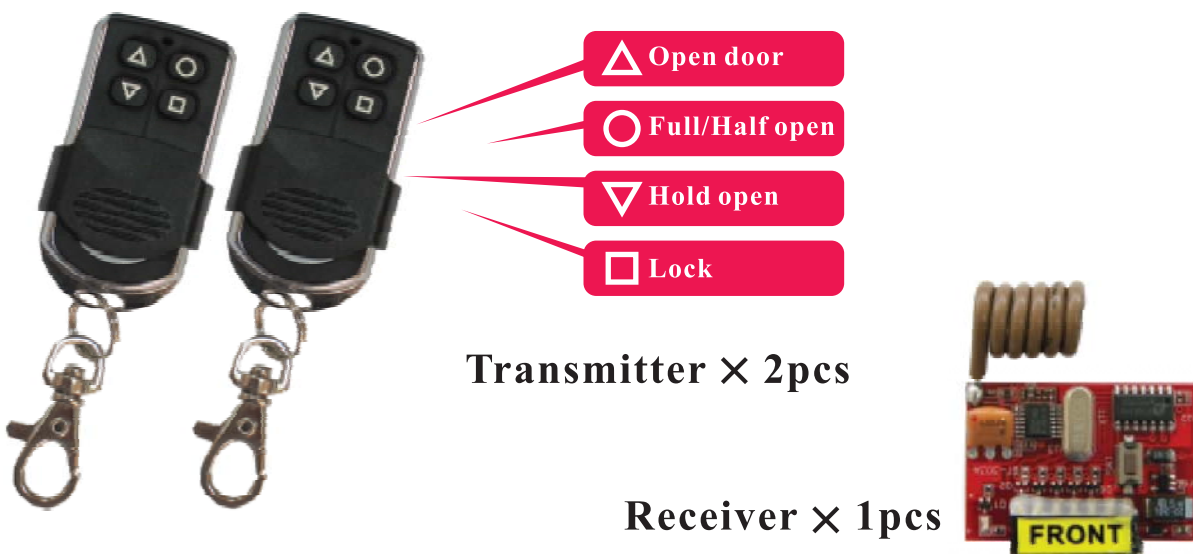

■ TH-136-MULTIFUNCTION DIGITAL SWITCH

1. Particular Memory Mode according different sessions to work.
2. Safety Alarm by itself to avoid danger happening.
3. Optional Language for easier operate in your location
4. Date and Time setting
5. Easy to install and program.
6. Beautiful and clear LCD panel
7. With buttons lock-on function

VOLUME	124.5X80X38.5(mm)
NET WEIGHT	0.46kg
ACCESSORIES	One piece of 5M cable



■ HTP-21C-SAFETY BEAM(HOTRON)

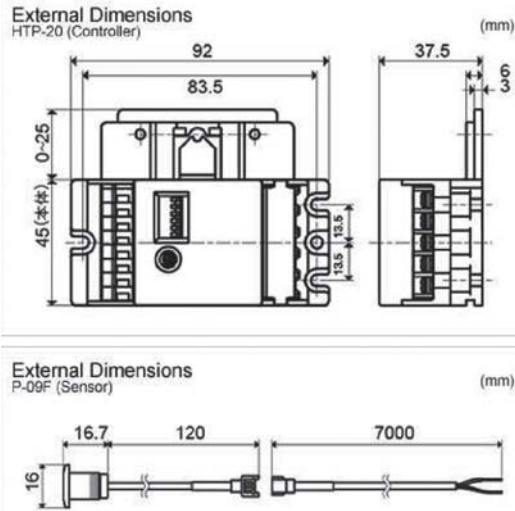

1. Beam sensor consisting of a controller and a single or dual set of infrared beams.
2. No need to use tools for wiring connection with compact controller.
3. Available to select penetration set-up or direct reflection set-up by setting switch.
4. Blink (under penetration setting), ON or OFF of LED tells you about the most suitable setting of volume adjustment by microcomputer control.

■ HR942D-INFRARED RAY SENSOR



1. The sensor body can be angled at up to 10° to ensure timely detection of fast moving traffic.
2. Presence timer settings adjustable to 2, 15 60 and 180 seconds.
3. The sensor microprocessor automatically takes countermeasures against adverse conditions such as falling snow and strong sunrays and electrical noise.
4. Quick installation and easy to adjust.
5. Active area is very specific with high degree of adjustment flexibility.
6. 12-24V AC-DC operations, Normal Open relay.
7. Simple design to suit with every Automatic Door.

■ HR100-CT-ACTIVATION+MONITORED SAFETY(HOTRON)

Advanced Unidirectional Detection Sensor with Monitored Safety and Unique "Door Learn" Ability



Pioneering super sensor offers pedestrian door activation and unprecedented safety at mounting heights of up to 3m

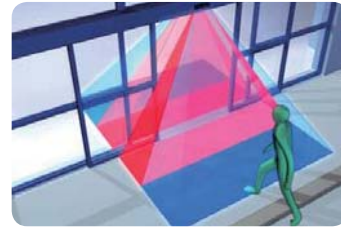

- **Energy Efficient**

Intelligent unidirectional detection ability reduces door hold open time by 20% and building energy loss by 6% in a standard installation.

- **Unparalleled Pedestrian Safety**

Unique ability to memorize door motion allows the infrared safety unparalleled pedestrian safety.

- **Versatile**

Flexibility to adjust the door activation and pedestrian safety detection zones independently makes the HR100-CT the ideal **sensor for every** sliding door installation

- **Ease of Installation**

All the information necessary to install the HR100-CT sensor is printed on the sensor body

■ HR94D1-C1- MONITORED SAFETY(HOTRON)

Monitored Sliding Door Side Screen or Door Threshold
Pedestrian Safety Sensor.



ACCESSORY FOR EN16005 OPERATORS



Versatile and simple to set up, the HR94D1-C1 protects pedestrians from the dangers of both opening and closing sliding doors at mounting heights of up to 3m

- Sliding Door Side Screen Pedestrian Safety**
 Protect pedestrians from the dangerous leading door edge during door open cycles with a dense curtain of infrared safety
- Door Threshold Pedestrian Safety**
 Safeguard pedestrians from hazardous door closures due to a shallow but wide infrared safety curtain that is monitored once per door cycle
- Solid & Reliable**
 Avoid the risk of loss or damage to individual sensor parts through a one piece sensor body construction
- Simple to Install**
 Install with ease without the need for a remote control thanks to comprehensive instructions printed on the sensor body

■ TH-201-MEGNETIC LOCKS

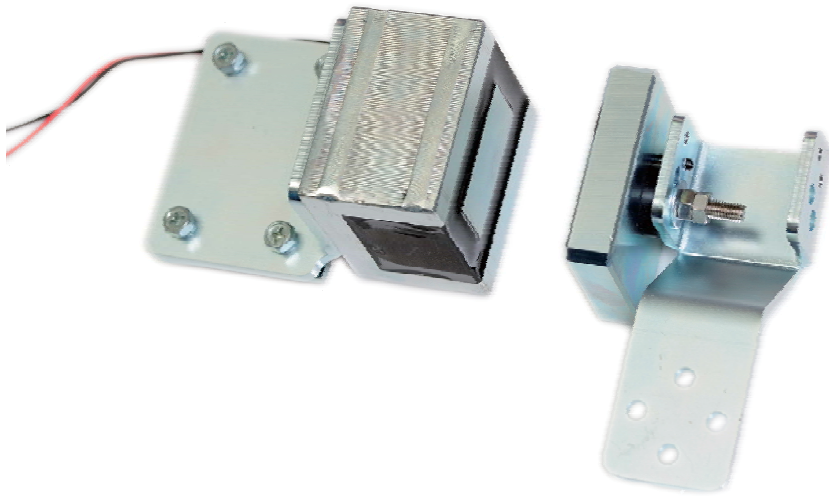

1. Main subject molded integrally and it can simplify installation procedures
2. Use aluminum alloy frame, strong crashworthy
3. Compact size, it can follow the installation (door type, sliding type)

■ TH-200LK-ELECTRIC BOLT

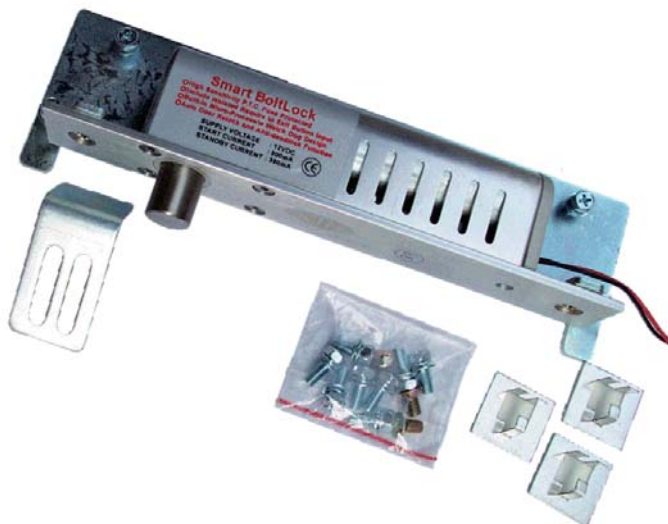

1. Don't increase the temperature while it running and working.
2. Tough and durable. There is no problems about the lock be lodged.

TH-135-FUNCTION KEY SWITCH



1. It's suitable any Door Operator of KTH.
2. Easy to install and adjust.

• SIX PRESS FUNCTION

- | | |
|---------------|----------------|
| 1. DOOR OPEN | 2. IN ONE-WAY |
| 3. AUTO | 4. OUT ONE-WAY |
| 5. DOOR CLOSE | 6. FULL/HALF |

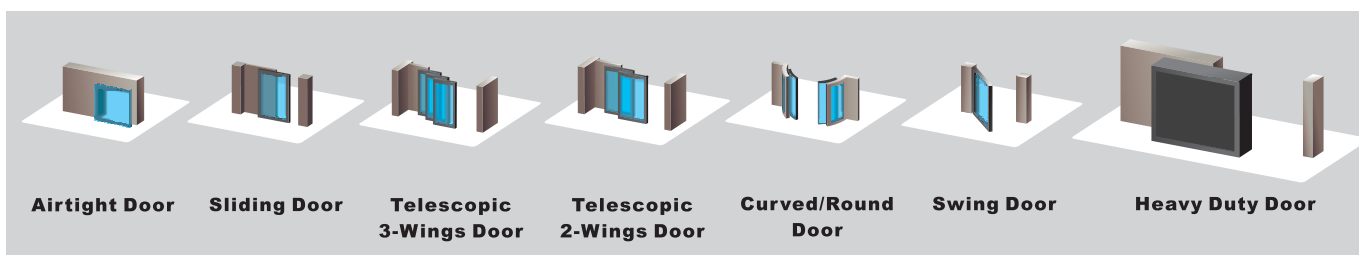

KTH KING TA HAN TECHNOLOGY CO., LTD

TEL:+886-7-8413699

FAX:+886-7-8413711

ADD:(80673) 2F-1,#286-8,Sinya Rd., Cianjhen District, Kaohsiung City, Taiwan